

Evaluating the efficiency and quality in primary care: A comparative study between Greek and Cypriot health centers

Panagiotis Mitropoulos^a, Panagiotis D. Zervopoulos^b and Ioannis Mitropoulos^a

^a Department of Business Administration, Technological Educational Institute of Western Greece, Greece

^b Department of International Trade, Bursa Orhangazi University, Turkey

Stream: Healthcare

4th International Symposium and 26th National Conference on Operational Research

Chania, Greece

4 - 6 June, 2015



European Union
European Social Fund



MINISTRY OF EDUCATION & RELIGIOUS AFFAIRS
MANAGING AUTHORITY

Co-financed by Greece and the European Union



programme for development
EUROPEAN SOCIAL FUND

This research has been co-financed by the European Union (European Social Fund - ESF) and Greek national funds through the Operational Program "Education and Lifelong Learning" of the National Strategic Reference Framework (NSRF) - Research Funding Program: ARCHIMEDES III. Investing in knowledge society through the European Social Fund.

1. The scope

- Development of a DEA-based performance measurement framework that takes into account both endogenous (i.e. efficiency) and exogenous (i.e. patients' satisfaction) variables.

Note: inverse relationship between endogenous and exogenous variables

- Construction of appropriate production frontiers in stochastic context.
- The appropriate production frontiers solely consist of units that are efficient and simultaneously are assigned desirable scores for their exogenous variables.

Note: Desirable are the scores that are at least equal to a user-defined threshold value

- While technical efficiencies of production units measured with respect to a given frontier are comparable, this is not normally the case among units that operate under different technologies. Hence in order to evaluate health units from different countries we extend the analysis in the metafrontier concept.

2. Methodology

- The methodology applied draws on the Quality-driven, Efficiency-adjusted DEA (QE-DEA) method (Zervopoulos and Palaskas, 2011).
- In the case of health data, the presence of noise is not uncommon.
- The data we use to measure the performance of the Greek and Cypriot primary care units (PCUs) both are endogenous (i.e. inputs and outputs) and exogenous (i.e. patients' satisfaction).
- Our methodology consists of three steps, which are as follows:

Step 1: Identification of 'disqualified' PCUs

Disqualified PCUs: efficient PCUs (i.e. $\eta \geq 1.000$) but fail to meet a threshold value ($\min(b_{kh}^d)^*$) for patients' satisfaction.

2. Methodology (Stochastic DEA)

min η

$$s.t. \quad \sum_{j=1}^n \lambda_j x_{ij} + \sum_{j=1}^n (E(x_{ij}) - x_{ij}) \lambda_j + \zeta \left(\sum_{j=1}^n \sum_{l=1}^n \lambda_j \lambda_l \text{cov}(x_{ij}, x_{pl}) \right)^{1/2} \leq \eta x_{ik}$$

$$\sum_{j=1}^n \lambda_j y_{rj} + \sum_{j=1}^n (E(y_{rj}) - y_{rj}) \lambda_j - \zeta \left(\sum_{j=1}^n \sum_{l=1}^n \lambda_j \lambda_l \text{cov}(y_{rj}, y_{ql}) \right)^{1/2} \geq y_{rk}$$

$$\lambda_j \neq 0$$

(1)

- The efficiency scores (η) obtained by program (1) are considered together with the patients' satisfaction scores assigned to the PCUs.

Step 2: Adjustment of 'disqualified' PCUs

- Increase of patients' satisfaction scores in order to become at least equal to a threshold value.
- If there are many dimensions of patients' satisfaction, the dimension that mostly deviates from the threshold ($\min(b_{kh}^d)$) should be set at least equal to the threshold value ($\min(b_{kh}^d)^*$)

2. Methodology (Quality adjustments)

- The adjustment of the dimensions of patients' satisfaction leads to a decrease in the efficiency score (η).
- The adjusted efficiency score is measured as follows:

$$(\eta_h)^{ad} = \eta_o + \left(\frac{(\min(b_{kh}^d) - b^*)^2 \cdot (\eta_o - \eta_h)^2 \cdot (\min(b_{kh}^d)^* - b^*)^2}{((\min(b_{kh}^d) - b^*)^2 + (\eta_o - \eta_h)^2) \cdot (\min(b_{kh}^d)^* - b^*)^2 - (\min(b_{kh}^d) - b^*)^2 \cdot (\eta_o - \eta_h)^2} \right)^{1/2} \quad (2)$$

- Drawing on the adjusted efficiency score ($(\eta_h)^{ad}$), the remaining dimensions of patients' satisfaction are defined as follows:

$$(b_{(k-1)h}^d)^{ad} = b^* + \left(\frac{((\eta_h)^{ad} - \eta_o)^2 \cdot (b_{(k-1)h}^d - b^*)^2 \cdot (\eta_o - \eta_h)^2}{((\eta_h)^{ad} - \eta_o)^2 \cdot ((b_{(k-1)h}^d - b^*)^2 + (\eta_o - \eta_h)^2) - (b_{(k-1)h}^d - b^*)^2 \cdot (\eta_o - \eta_h)^2} \right)^{1/2} \quad (3)$$

where $(b_{(k-1)h}^d)^{ad}$ stands for the adjusted scores of the remaining disqualified dimension(s) (i.e. $k-1$)

2. Methodology (Combined model)

$$(b_{lh}^q)^{ad} = b^* + \left(\frac{((\eta_h)^{ad} - \eta_o)^2 \cdot (b_{lh}^q - b^*)^2 \cdot (\eta_o - \eta_h)^2}{((\eta_h)^{ad} - \eta_o)^2 \cdot ((b_{lh}^q - b^*)^2 + (\eta_o - \eta_h)^2) - (b_{lh}^q - b^*)^2 \cdot (\eta_o - \eta_h)^2} \right)^{1/2} \quad (4)$$

where $(b_{lh}^q)^{ad}$ denotes the adjusted score assigned to the qualified dimension(s)

Step 3: Measurement of performance

min θ

$$s.t. \quad \sum_{j=1}^n \lambda_j X_{ij} + \sum_{j=1}^n (E(X_{ij}) - X_{ij}) \lambda_j + \zeta \left(\sum_{j=1}^n \sum_{l=1}^n \mu_j \mu_l \text{cov}(X_{ij}, X_{pl}) \right)^{1/2} \leq \theta X_{ik}$$

$$\sum_{j=1}^n \lambda_j y_{rj} + \sum_{j=1}^n (E(y_{rj}) - y_{rj}) \lambda_j - \zeta \left(\sum_{j=1}^n \sum_{l=1}^n \lambda_j \lambda_l \text{cov}(y_{rj}, y_{ql}) \right)^{1/2} \geq y_{rk}$$

$$\sum_{j=1}^n \lambda_j B_{tj} + \sum_{j=1}^n (E(B_{tj}) - B_{tj}) \lambda_j - \zeta \left(\sum_{j=1}^n \sum_{l=1}^n \mu_j \mu_l \text{cov}(B_{tj}, B_{ql}) \right)^{1/2} \geq \theta B_{tk}$$

$$\lambda_j \neq 0$$

(5)

where $t, z = 1, \dots, w$; $\mu_j = \begin{cases} \lambda_j, & j=1, \dots, n \ (j \neq k) \\ \lambda_j - \theta, & j=k \end{cases}$ and $\mu_l = \begin{cases} \lambda_l, & l=1, \dots, n \ (l \neq k) \\ \lambda_l - \theta, & l=k \end{cases}$

2. Methodology (Combined model)

- Program (5) incorporates all inputs (i.e. $X_{ij} = x_{i(j \neq h)} + x_{ih}^{ad}$), outputs and dimensions of patients' satisfaction (i.e. $B_{ij} = b_{(t \neq k, l)(j \neq h)} + \min(b_{kh}^d)^* + (b_{(k-1)h}^d)^{ad} + (b_{lh}^q)^{ad}$).
- Program (5) secures the symmetric handling of the inputs and the dimensions of patients' satisfaction.

2. Methodology (Metafrontier)

- While technical efficiencies of production units measured with respect to a given frontier are comparable, this is not normally the case among units that operate under different technologies
- We filtering out differences that are caused by inefficiencies rather than heterogeneities due to exogenous influences
- Metafrontier can be described as a function that “envelops” separate group frontiers, each having their own technology and environmental factors (O’Donnell et al., 2007)
 - $k(>1)$ groups
 - TE_r^k : Technical efficiency of unit r relative to frontier k
 - TE_r^* : Technical efficiency of unit r relative to metafrontier
 - TGR_r^* : Technology gap ratio (TGR)

$$TGR_r^* = \frac{TE_r^*}{TE_r^k}$$

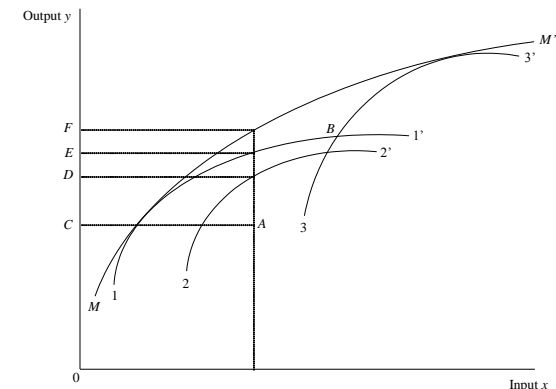

3.1. Numerical example: Data set

- 15 Cypriot PCUs and 16 Greek PCUs
- 3 inputs (i.e. (a) number of medical doctors (FTE), (b) number of nurses (FTE) and (c) number of other staff (FTE))
- 2 outputs (i.e. (a) number of admissions and (b) number of medical examinations & vaccinations)
- 4 dimensions of patients' satisfaction (i.e. (a) arrangement of appointment with a medical doctor, (b) arrangement of appointment for medical examinations from referral, (c) health center (tangibles) and medical examinations, and (d) radiological & laboratory (R&L) examinations)
- Number of patients' satisfaction questionnaires collected: 428 for the Cypriot PCUs and 1600 for the Greeks PCUs

3.2. Numerical example: Empirical results

- Step 1: Identification of ‘disqualified’ PCUs

Table 1. Classification of the Cypriot PCUs

ID	Health Centers	Efficiency	D1	D2	D3	D4	Status
1	Nicosia (Old hospital)	0.5719	0.8221	0.8093	0.9116	0.8273	LE-HD1-HD2-HD3-HD4
2	St. Dometios	1.1193	0.7344	0.7811	0.8323	0.7356	HE- LD1-LD2 -HD3- LD4
3	Strovolos	0.6187	0.8485	0.8375	0.8790	0.8554	LE-HD1-HD2-HD3-HD4
4	Kaimakli	0.8119	0.7930	0.8251	0.8636	0.7965	LE-LD1-HD2-HD3-LD4
5	Latsia	1.3904	0.8846	0.8505	0.9261	0.7535	HE-HD1-HD2-HD3- LD4
6	Dali	0.9833	0.9400	0.9300	0.9322	1.0000	LE-HD1-HD2-HD3-HD4
7	Akaki	1.0255	0.8031	0.7933	0.8923	0.8272	HE-HD1- LD2 -HD3-HD4
8	Lakatamia	0.7077	0.7865	0.8336	0.8476	0.7767	LE-LD1-HD2-HD3-LD4
9	Limasol (Old hospital)	1.2056	0.5816	0.5738	0.6769	0.5328	HE- LD1-LD2-LD3-LD4
10	Agros	0.8196	0.8000	0.8867	0.8963	0.8480	LE-HD1-HD2-HD3-HD4
11	Plastres	1.3298	0.8978	0.9227	0.8722	0.8630	HE-HD1-HD2-HD3-HD4
12	Larnaca (Old hospital)	1.1175	0.8038	0.7996	0.8257	0.7895	HE-HD1- LD2 -HD3- LD4
13	Kofinou	1.0080	0.9126	0.9295	0.9525	0.9033	HE-HD1-HD2-HD3-HD4
14	Panagia	0.6018	0.8056	0.8280	0.8294	0.8100	LE-HD1-HD2-HD3-HD4
15	Ormidia	1.8226	0.8003	0.7745	0.8100	0.7926	HE-HD1- LD2 -HD3- LD4

D1: arrangement of appointment with a medical doctor

D2: arrangement of appointment for medical examinations from referral

D3: health center (tangibles) & medical examinations

D4: R&L examinations

Note: The threshold that distinguishes the desirable scores (i.e. HD) from the undesirable scores (i.e. LD) is 0.800

3.2. Numerical example: Empirical results

Table 2. Classification of the Greek PCUs

ID	Health Centers	Efficiency	D1	D2	D3	D4	Status
1	Astakos	0.5166	0.7136	0.8048	0.8323	0.7411	LE-LD1-HD2-HD3-LD4
2	Etoliko	0.6547	0.4417	0.7128	0.8064	0.7690	LE-LD1-LD2-HD3-LD4
3	Akrata	0.5393	0.7960	0.8799	0.8808	0.8220	LE-LD1-HD2-HD3-HD4
4	Amfilochia	1.0662	0.7020	0.6859	0.7701	0.6187	HE-LD1-LD2-LD3-LD4
5	Varda	1.1801	0.6374	0.5895	0.7277	0.6108	HE-LD1-LD2-LD3-LD4
6	Vonitsa	0.4531	0.6383	0.5855	0.7313	0.6529	LE-LD1-LD2-LD3-LD4
7	Erimanthia	0.9702	0.4000	0.8634	0.8787	0.7594	LE-LD1-HD2-HD3-LD4
8	Kato Achaia	0.3286	0.4417	0.7061	0.7991	0.7652	LE-LD1-LD2-LD3-LD4
9	Nafpaktos	0.8217	0.6606	0.5956	0.7611	0.6968	LE-LD1-LD2-LD3-LD4
10	Simopoulos	1.7459	0.6432	0.6021	0.7354	0.6529	HE-LD1-LD2-LD3-LD4
11	Thermos	0.3640	0.8051	0.8941	0.8984	0.8538	LE-HD1-HD2-HD3-HD4
12	Chalandritsa	1.8225	0.7300	0.8140	0.8392	0.7382	HE-LD1-HD2-HD3-LD4
13	Chalkiopoulos	0.5845	0.4000	0.8539	0.8758	0.7366	LE-LD1-HD2-HD3-LD4
14	Gastouni	0.3672	0.6521	0.6046	0.7607	0.7184	LE-LD1-LD2-LD3-LD4
15	Archaia Olympia	0.2221	0.6200	0.7716	0.8011	0.5858	LE-LD1-LD2-HD3-LD4
16	Kletoria	0.3791	0.8417	0.8190	0.8425	0.8753	LE-HD1-HD2-HD3-HD4

3.2. Numerical example: Empirical results

Table 3. Classification of the Cypriot and Greek PCUs

ID	Health Centers	Efficiency	D1	D2	D3	D4	Status
1	Nicosia (Old hospital)	0.5719	0.8221	0.8093	0.9116	0.8273	LE-HD1-HD2-HD3-HD4
2	St. Dometios	1.1193	0.7344	0.7811	0.8323	0.7356	HE-LD1-LD2-HD3-LD4
3	Strovolos	0.6187	0.8485	0.8375	0.8790	0.8554	LE-HD1-HD2-HD3-HD4
4	Kaimakli	0.8119	0.7930	0.8251	0.8636	0.7965	LE-LD1-HD2-HD3-LD4
5	Latsia	1.3015	0.8846	0.8505	0.9261	0.7535	HE-HD1-HD2-HD3-LD4
6	Dali	0.9833	0.9400	0.9300	0.9322	1.0000	LE-HD1-HD2-HD3-HD4
7	Akaki	0.9841	0.8031	0.7933	0.8923	0.8272	LE-HD1-LD2-HD3-HD4
8	Lakatamia	0.7077	0.7865	0.8336	0.8476	0.7767	LE-LD1-HD2-HD3-LD4
9	Limasol (Old hospital)	1.2056	0.5816	0.5738	0.6769	0.5328	HE-LD1-LD2-LD3-LD4
10	Agros	0.8196	0.8000	0.8867	0.8963	0.8480	LE-HD1-HD2-HD3-HD4
11	Plastres	1.2445	0.8978	0.9227	0.8722	0.8630	HE-HD1-HD2-HD3-HD4
12	Larnaca (Old hospital)	1.1175	0.8038	0.7996	0.8257	0.7895	HE-HD1-LD2-HD3-LD4
13	Kofinou	1.0080	0.9126	0.9295	0.9525	0.9033	HE-HD1-HD2-HD3-HD4
14	Panagia	0.6018	0.8056	0.8280	0.8294	0.8100	LE-HD1-HD2-HD3-HD4
15	Ormidia	1.8226	0.8003	0.7745	0.8100	0.7926	HE-HD1-LD2-HD3-LD4
16	Astakos	0.2424	0.7136	0.8048	0.8323	0.7411	LE-LD1-HD2-HD3-LD4
17	Etoliko	0.4828	0.4417	0.7128	0.8064	0.7690	LE-LD1-LD2-HD3-LD4
18	Akrata	0.5393	0.7960	0.8799	0.8808	0.8220	LE-LD1-HD2-HD3-HD4
19	Amfilochia	0.9875	0.7020	0.6859	0.7701	0.6187	LE-LD1-LD2-LD3-LD4
20	Varda	1.0512	0.6374	0.5895	0.7277	0.6108	HE-LD1-LD2-LD3-LD4
21	Vonitsa	0.2375	0.6383	0.5855	0.7313	0.6529	LE-LD1-LD2-LD3-LD4
22	Erimanthia	0.4663	0.4000	0.8634	0.8787	0.7594	LE-LD1-HD2-HD3-LD4
23	Kato Achaia	0.2684	0.4417	0.7061	0.7991	0.7652	LE-LD1-LD2-LD3-LD4
24	Nafpaktos	0.7050	0.6606	0.5956	0.7611	0.6968	LE-LD1-LD2-LD3-LD4
25	Simopoulos	1.7459	0.6432	0.6021	0.7354	0.6529	HE-LD1-LD2-LD3-LD4
26	Thermos	0.2991	0.8051	0.8941	0.8984	0.8538	LE-HD1-HD2-HD3-HD4
27	Chalandritsa	1.8225	0.7300	0.8140	0.8392	0.7382	HE-LD1-HD2-HD3-LD4
28	Chalkiopoulos	0.2761	0.4000	0.8539	0.8758	0.7366	LE-LD1-HD2-HD3-LD4
29	Gastouni	0.3190	0.6521	0.6046	0.7607	0.7184	LE-LD1-LD2-LD3-LD4
30	Archaia Olympia	0.2221	0.6200	0.7716	0.8011	0.5858	LE-LD1-LD2-HD3-LD4
31	Kletoria	0.1790	0.8417	0.8190	0.8425	0.8753	LE-HD1-HD2-HD3-HD4

3.2. Numerical example: Empirical results

▪ Step 2: Adjustment of ‘disqualified’ PCUs

Table 4. Adjusted efficiency and satisfaction scores

Cypriot PCUs										
ID	Efficiency		D1		D2		D3		D4	
	(ζ)	(ζ')	Actual	Adjusted	Actual	Adjusted	Actual	Adjusted	Actual	Adjusted
2	1.1193	0.9240	0.7344	0.8000	0.7811	0.8686	0.8323	0.9502	0.7356	0.8017
5	1.3904	1.1159	0.8846	0.9792	0.8505	0.9299	0.9261	1.0000	0.7535	0.8000
7	1.0255	1.0082	0.8031	0.8102	0.7933	0.8000	0.8923	0.9030	0.8272	0.8351
9	1.2056	0.5716	0.5816	1.0000	0.5738	1.0000	0.6769	0.9338	0.5328	0.8000
12	1.1175	1.0812	0.8038	0.8151	0.7996	0.8107	0.8257	0.8383	0.7895	0.8000
15	1.8226	1.4578	0.8003	0.8296	0.7745	0.8000	0.8100	0.8409	0.7926	0.8208
Greek PCUs										
ID	Efficiency		D1		D2		D3		D4	
	(ζ)	(ζ')	Actual	Adjusted	Actual	Adjusted	Actual	Adjusted	Actual	Adjusted
4	1.0662	0.6846	0.7020	1.0000	0.6859	1.0000	0.7701	1.0000	0.6187	0.8000
5	1.1801	0.6539	0.6374	1.0000	0.5895	0.8000	0.7277	1.0000	0.6108	0.8879
10	1.7459	0.7113	0.6432	0.9705	0.6021	0.8000	0.7354	1.0000	0.6529	1.0000
12	1.8225	1.1279	0.7300	0.8000	0.8140	0.9310	0.8392	0.9747	0.7382	0.8119
Cypriot & Greek PCUs										
ID	Efficiency		D1		D2		D3		D4	
	(ζ)	(ζ')	Actual	Adjusted	Actual	Adjusted	Actual	Adjusted	Actual	Adjusted
2	1.1193	0.9240	0.7344	0.8000	0.7811	0.8686	0.8323	0.9502	0.7356	0.8017
5	1.3015	1.0735	0.8846	0.9792	0.8505	0.9299	0.9261	1.0000	0.7535	0.8000
9	1.2056	0.5716	0.5816	1.0000	0.5738	1.0000	0.6769	0.9338	0.5328	0.8000
12	1.1175	1.0812	0.8038	0.8151	0.7996	0.8107	0.8257	0.8383	0.7895	0.8000
15	1.8226	1.4578	0.8003	0.8296	0.7745	0.8000	0.8100	0.8409	0.7926	0.8208
20	1.0512	0.6388	0.6374	1.0000	0.5895	0.8000	0.7277	1.0000	0.6108	0.8879
25	1.7459	0.7113	0.6432	0.9705	0.6021	0.8000	0.7354	1.0000	0.6529	1.0000
27	1.8225	1.1279	0.7300	0.8000	0.8140	0.9310	0.8392	0.9747	0.7382	0.8119

3.2. Numerical example: Empirical results

- Step 3: Measurement of performance

Table 5a. Cypriot and Greek PCUs: Benchmarking and projection of satisfaction dimensions

ID	Performance (θ)	D1			D2			D3			D4		
		Actual	Adjusted	Projected	Actual	Adjusted	Projected	Actual	Adjusted	Projected	Actual	Adjusted	Projected
1	1.1331	0.8221	0.8221	0.9316	0.8093	0.8093	0.9171	0.9116	0.9116	1.0330	0.8273	0.8273	0.9375
2	1.3460	0.7344	0.8000	1.0768	0.7811	0.8686	1.1692	0.8323	0.9502	1.2789	0.7356	0.8017	1.0790
3	1.1589	0.8485	0.8485	0.9833	0.8375	0.8375	0.9705	0.8790	0.8790	1.0187	0.8554	0.8554	0.9913
4	1.2589	0.7930	0.7930	0.9983	0.8251	0.8251	1.0388	0.8636	0.8636	1.0872	0.7965	0.7965	1.0027
5	0.8118	0.8846	0.9792	0.5671	0.8505	0.9299	0.5971	0.9261	1.0000	0.6449	0.7535	0.8000	0.5659
6	1.3132	0.9400	0.9400	0.9598	0.9300	0.9300	0.9707	0.9322	0.9322	1.0004	1.0000	1.0000	0.9919
7	0.8665	0.8031	0.8031	0.7495	0.7933	0.7933	0.7884	0.8923	0.8923	0.8538	0.8272	0.8272	0.7485
8	0.9169	0.7865	0.7865	0.9718	0.8336	0.8336	1.0074	0.8476	0.8476	1.0748	0.7767	0.7767	0.9732
9	1.0723	0.5816	1.0000	1.0723	0.5738	1.0000	1.0723	0.6769	0.9338	1.0013	0.5328	0.8000	0.8578
10	1.2833	0.8000	0.8000	0.7488	0.8867	0.8867	0.7686	0.8963	0.8963	0.7886	0.8480	0.8480	0.7602
11	0.6844	0.8978	0.8978	0.3782	0.9227	0.9227	0.3677	0.8722	0.8722	0.3841	0.8630	0.8630	0.3750
12	1.0354	0.8038	0.8151	1.2246	0.7996	0.8107	1.2515	0.8257	0.8383	1.3113	0.7895	0.8000	1.1955
13	1.2321	0.9126	0.9126	0.9899	0.9295	0.9295	1.0154	0.9525	0.9525	1.0515	0.9033	0.9033	0.9858
14	1.3495	0.8056	0.8056	1.0871	0.8280	0.8280	1.1174	0.8294	0.8294	1.1192	0.8100	0.8100	1.0931
15	1.3959	0.8003	0.8296	1.1580	0.7745	0.8000	1.1167	0.8100	0.8409	1.1738	0.7926	0.8208	1.1457
16	1.1331	0.7136	0.7136	0.8085	0.8048	0.8048	0.9119	0.8323	0.8323	0.9431	0.7411	0.7411	0.8397

3.2. Numerical example: Empirical results

Table 5b. Cypriot and Greek PCUs: Benchmarking and projection of satisfaction dimensions

ID	Performance (θ)	D1			D2			D3			D4		
		Actual	Adjusted	Projected	Actual	Adjusted	Projected	Actual	Adjusted	Projected	Actual	Adjusted	Projected
17	0.5235	0.4417	0.4417	1.5510	0.7128	0.7128	1.5916	0.8064	0.8064	1.6919	0.7690	0.7690	1.5590
18	0.2888	0.7960	0.7960	0.3708	0.8799	0.8799	0.3901	0.8808	0.8808	0.4052	0.8220	0.8220	0.3478
19	0.5357	0.7020	0.7020	1.8120	0.6859	0.6859	1.8711	0.7701	0.7701	1.9751	0.6187	0.6187	1.8315
20	0.4738	0.6374	1.0000	0.6378	0.5895	0.8000	0.6810	0.7277	1.0000	0.7233	0.6108	0.8879	0.6119
21	0.8965	0.6383	0.6383	0.7585	0.5855	0.5855	0.8674	0.7313	0.7313	0.8899	0.6529	0.6529	0.8142
22	1.0731	0.4000	0.4000	0.3895	0.8634	0.8634	0.4535	0.8787	0.8787	0.4890	0.7594	0.7594	0.4380
23	0.6365	0.4417	0.4417	1.8404	0.7061	0.7061	1.8803	0.7991	0.7991	1.9921	0.7652	0.7652	1.8514
24	0.3850	0.6606	0.6606	1.4593	0.5956	0.5956	1.5065	0.7611	0.7611	1.5881	0.6968	0.6968	1.4759
25	0.9254	0.6432	0.9705	0.5436	0.6021	0.8000	0.5848	0.7354	1.0000	0.5825	0.6529	1.0000	0.5117
26	0.5359	0.8051	0.8051	2.0316	0.8941	0.8941	2.0822	0.8984	0.8984	2.2110	0.8538	0.8538	2.0437
27	0.4767	0.7300	0.8000	0.2974	0.8140	0.9310	0.3049	0.8392	0.9747	0.3000	0.7382	0.8119	0.2557
28	1.1130	0.4000	0.4000	0.5637	0.8539	0.8539	0.7828	0.8758	0.8758	0.8057	0.7366	0.7366	0.7072
29	0.4167	0.6521	0.6521	0.9730	0.6046	0.6046	1.0064	0.7607	0.7607	1.0504	0.7184	0.7184	0.9807
30	0.4616	0.6200	0.6200	0.1574	0.7716	0.7716	0.1776	0.8011	0.8011	0.1836	0.5858	0.5858	0.1635
31	0.8613	0.8417	0.8417	0.4510	0.8190	0.8190	0.4495	0.8425	0.8425	0.4608	0.8753	0.8753	0.4141

3.2. Numerical example: Metafrontier analysis

		Group Frontiers		Metafrontier		TGR	
		Step 1	Final Step	Step 1	Final Step	Step 1	Final Step
Cypriot HCs	Mean	1,01	1,12	0,99	1,12	0,99	1,00
	St.dev	0,34	0,22	0,33	0,22	0,02	0,01
	Max	1,82	1,40	1,82	1,40	1,00	1,02
	Min	0,57	0,68	0,57	0,68	0,94	0,99
Greek HCs	Mean	0,75	0,98	0,62	0,67	0,77	0,68
	St.dev	0,49	0,24	0,53	0,28	0,21	0,22
	Max	1,82	1,29	1,82	1,13	1,00	1,00
	Min	0,22	0,46	0,18	0,29	0,47	0,37
Overall	Mean	0,80	0,89				
	St.dev	0,48	0,34				
	Max	1,82	1,40				
	Min	0,18	0,29				

- In step1 the mean TGR differences between Greek and Cypriot HCs = $=0,99-0,77=0,22$. Hence the technology gap is 0,22
- In final step the mean TGR differences between Greek and Cypriot HCs = $=1-0,68=0,32$. Hence the technology gap when we incorporate the quality is increased further by 10%.

3.2. Numerical example: Empirical results

- The stochastic performance measurement framework managed to construct a production frontier in which 11 out of the 14 benchmark PCUs both meet the efficiency and patients' satisfaction criteria.
- Originally, 8 out of the 10 benchmark PCUs failed to meet the efficiency and patients' satisfaction criteria.
- The 3 efficient PCUs that fail to meet the patients' satisfaction threshold value (i.e. 0.800) report lower optimal inputs compared to their original input levels.
- The decreased optimal number of medical doctors and nurses has negative impact on the four dimensions of patients' satisfaction.
- The Greek PCUSs face a large technology gap in both efficiency and quality evaluations.

Thank you!